

FEATURES

- Voltage Measurement Range: 0 to ±1000V
- Output Voltage Range: 0 to ±10V
- Both AC and DC Voltage Measurement
- Galvanic Isolated Voltage Rating: 4200 Vrms
- Very Low Leakage Current: < 40uA
- Large Signal Bandwidth: 50KHz
- Overall Accuracy: ±0.1% of Full Scale
- High Capacitance Load Drive (10nF)-Long Cable
- Fast Response Time: 3μS Delay 6us Rise/Fall
- Very Low Nonlinearity: ±0.0005% Max
- High Common Mode Voltage Rejection: 110dB
- High Input Resistance: 1.5 MΩ
- Operating Temperature Range: -40°C to 85°C
- Low Output Voltage Offset Drift: ±42μV/ °C
- Very Low Voltage Gain Drift: ±0.0055%/ °C
- Operating Power Supply Range: ±11V to ±16V
- Low Quiescent Current: <45mA/2.8mA VCC/VEE
- Built-in Isolated Power Supply
- Low Profile Footprint: 1.62"x0.95"x0.531"
- Weight: 22g (0.776 OZ)
- RoHS Compliant
- MTBF 1575 x10³ Hrs(25°C) 823 x10³ Hrs(85°C)
- Excellent Water and Thermal Shock Resistance
- Flame Retardant(UL 94 V-O)

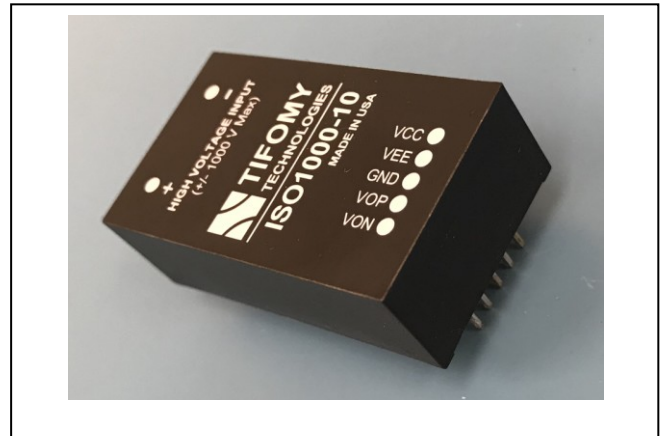
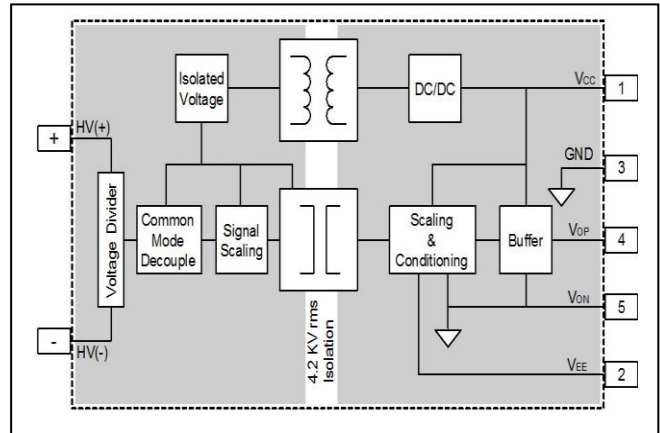

DESCRIPTION

ISO1000-10 is a high precision high bandwidth voltage transducer that is capable of measuring AC and DC voltages up to ± 1000V with ± 0.1% accuracy. The device is rated 4.2KV rms galvanic isolation with advanced voltage sensing, common mode decoupling, and isolation technology built-in to ensure safe and accurate high voltage measurement. Excellent dynamic characteristics provide large signal bandwidth of 50 KHz and high common mode rejection of 110 dB @ 60Hz. The ISO1000-10 is ideal for high voltage sensing that requires high accuracy, fast response, high common mode rejection, wide operating temperatures (- 40 °C to 85 °C), and a small footprint.

The ISO1000-10 is easy to use and does not require additional components. The device has an internal integrated isolation power supply and circuitry for direct high voltage sensing. Just apply nominal ± 12Vdc power and high voltage to be sensed, the device will output a galvanic isolated voltage signal with voltage attenuation gain of 100. High voltage input pins are "+" and "-" with maximum differential voltage of ± 1000V and voltage rated 4.2KV rms with respect to ground. Operating power supply requirement is ± 12Vdμc nominal (range: ± 11V to ± 16V). Pin "VCC" is +12V input, Pin "VEE" is -12V input, and pin "GND" is ± 12V return or GND. Pin "VOP" (reference to Pin "VON") is the output with full scale output voltage of ± 10V. Pins "+", "-", and Pins "VCC", "VEE", "GND", "VOP", "VON" are isolated with reinforced insulation of 4.2KVrms isolation rating.

Output to input voltage gain is 1:100. The ISO1000-10 has excellent gain linearity with typical ± 0.0002% nonlinearity (±100V to ±1000V) and maximum ± 0.0005% nonlinearity at low voltage range (< ±100V). Gain deviation as a function of temperature is typically ± 0.0055% /°C. Output voltage offset

drift is typically $\pm 42\mu\text{V}/^\circ\text{C}$.

High voltage input resistance is typical 1.5 MΩ and it requires very small power from high voltage bus circuit being sensed. For example, power drawn from a 1000Vdc high voltage bus is 0.67 watts. The input resistance is optimized with dynamic characteristics, DC characteristics, and thermal performance of the device.

The ISO1000-10 requires small quiescent current (41 mA @ +12V) from its VCC input power supply and 2.7 mA max from VEE. The internal integrated isolation power supply is derived from the VCC input to power up high voltage side circuitry.

FUNCTIONAL BLOCK DIAGRAM

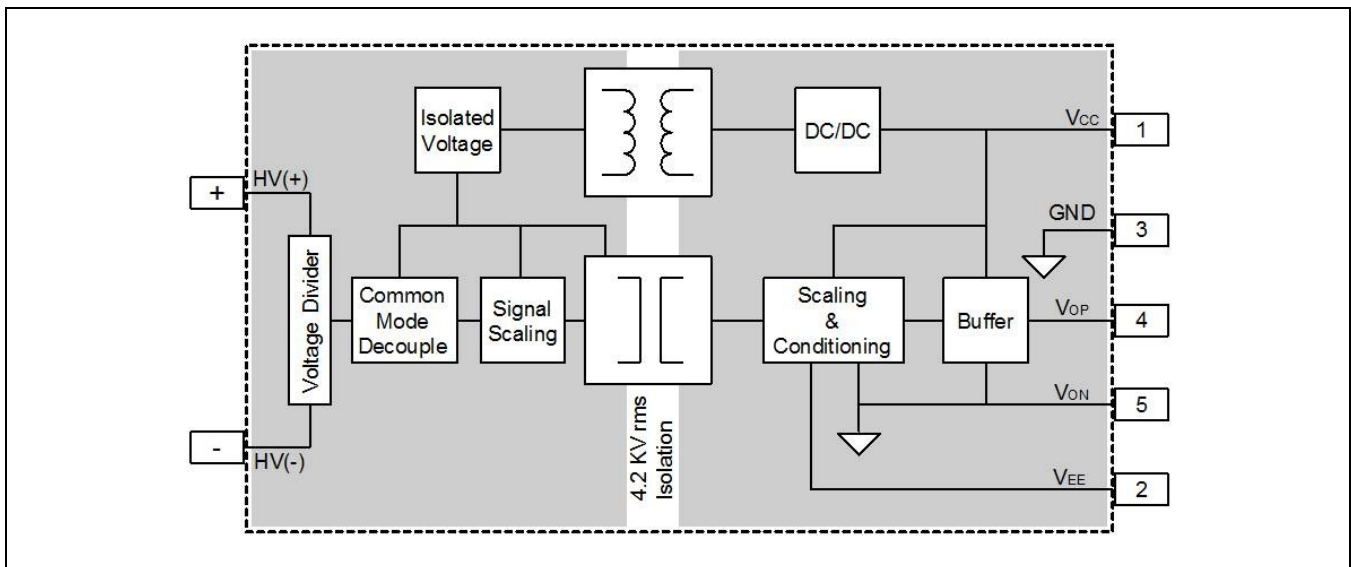

TYPICAL APPLICATION WIRING DIAGRAM

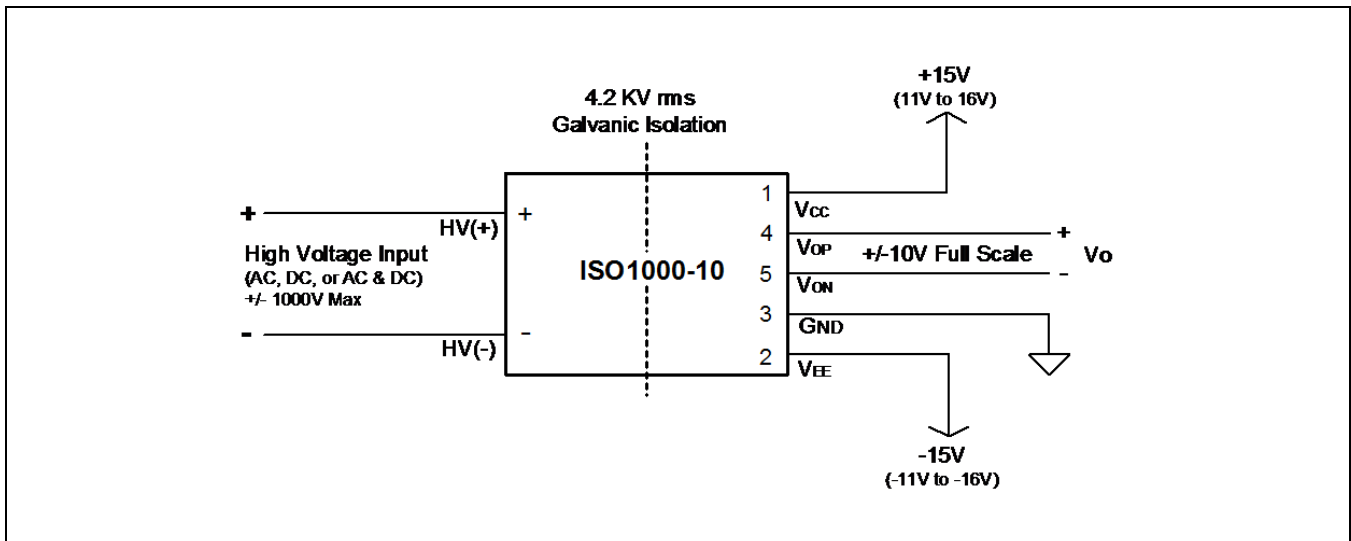

ABSOLUTE MAXIMUM RATINGS

Parameter	Symbol	Minimum	Maximum	Units
Storage Temperature	TS	-45	+ 95	°C
Ambient Operating Temperature	TA	-40	+ 85	°C
Supply Voltages	VCC [Pin 1]	11	16	V
	VEE [Pin 2]	-11	-16	V
	GND [Pin 3]	0	0.2	V
Steady State Input Voltage	[Pin +] - [Pin -]	-1050	+ 1050	V
Transient Input Voltage (30 Seconds)	[Pin +] - [Pin -]	-1200	+ 1200	V
Output Voltage	Vo [Pin 4]-[Pin 5]	-16	16	V
Pins Soldering	Temperature		260	°C
	Time Duration		15	S

RECOMMENDED OPERATING CONDITIONS

Parameter	Symbol	Minimum	Maximum	Units
Ambient Operating Temperature	TA	-40	+ 85	°C
Supply Voltages	VCC [Pin 1]	12	15	V
	VEE [Pin 2]	-12	-15	V
Input Voltage Range	[Pin +] - [Pin -]	-1000	1000	V

ELECTRICAL CHARACTERISTICS

At TA = +25°C, Vcc = +12V VEE=-12V, and RL = 10kΩ, unless otherwise noted

PARAMETER	CONDITIONS	Fig	Note	ISO1000-10			UNITS	
				MIN	TYP	MAX		
ISOLATION								
Isolation Voltage Rating	Input to Output, 60Hz AC, 60sec 100% Tested	17	1	4200			Vrms	
Leakage Current	Input to Output, 4200 Vrms @ 60Hz				28	40	µA rms	
GAIN								
Nominal Gain	Output to Input Voltage Ratio	1-2	2		1/100		V/V	
Overall Accuracy		3	3			±0.1	%	
Gain Vs Temperature	-40 °C to 85 °C	6	4			±0.0055	% / °C	
Nonlinearity		4	5		±0.0002	±0.0005	%	
COMMON MODE REJECTION								
Frequency Response	60Hz 10KHz 500KHz	16,19	6		110 75 56		dB dB dB	
Transient Immunity	1000V Step Excitation	15,20	7		1		V	
INPUT VOLTAGE								
Voltage Range	Continuous Operation	18	8			±1000	V	
Resistance	Between Pin "+" and Pin "-"				1.5		MΩ	
OUTPUT VOLTAGE								
Voltage Range						± 10	V	
Offset Voltage						± 5	mV	
Voltage Offset Drift	Deviation from offset @ 25°C	18	9		± 42		µV / °C	
Current Drive					±10		mA	
Capacitive Load	In parallel with 2KΩ				10		nF	
Ripple Voltage	Vin=0V with 2K 1nF RC Filter				±10		mV	
DYNAMIC RESPONSE								
Large Signal Bandwidth	Vin Amplitude:1000V	7-12	10		50		KHz	
Propagation Delay	Pulse Transient Test	13-14 22	11		3		µS	
Slew Rate			11		2.5		V / µS	
POWER SUPPLY								
Supply Voltage	Rated Input Voltage Range				±11	±12	±15	V
Quiescent Current (VCC)					40.1	40.7	42.2	mA
Quiescent Current (VEE)					2.7	2.7	2.7	mA
Temperature Range								
Operating	Continuous Full Input Voltage				- 40		85	°C
Storage	Non-Power				- 45		95	°C

PERFORMANCE CHARACTERISTICS

At $T_A = +25^\circ\text{C}$, $V_{CC} = +12\text{V}$, $V_{EE} = -12\text{V}$, and $R_L = 10\text{k}\Omega$, unless otherwise noted

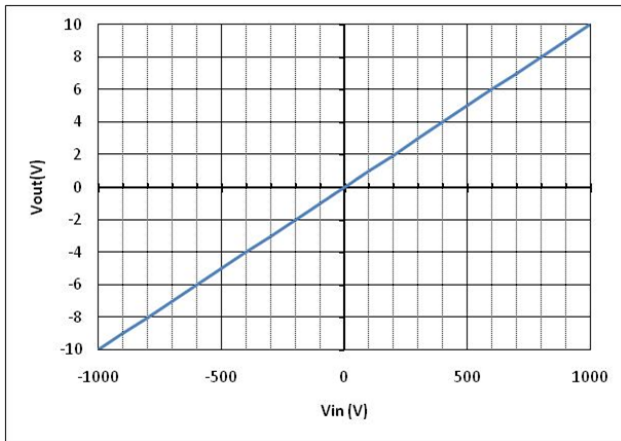

Figure 1: Input to Output Voltage

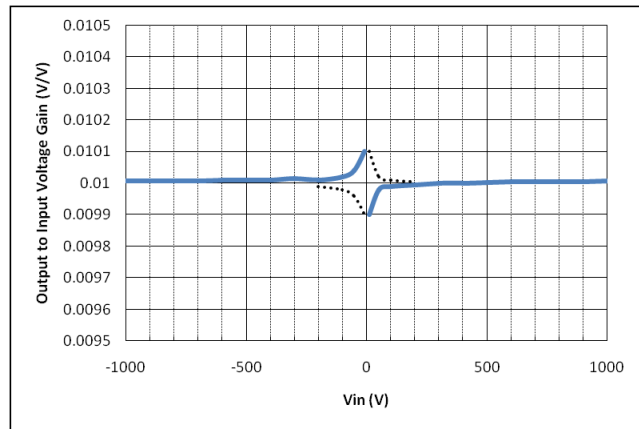

Figure 2: Output to Input Voltage Gain

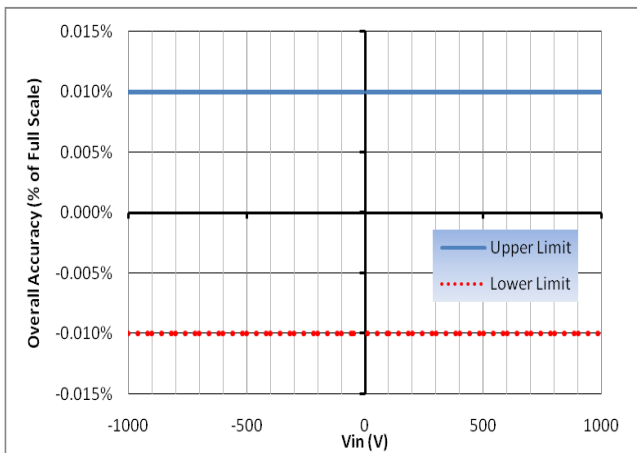

Figure 3: Voltage Sensing Overall Accuracy

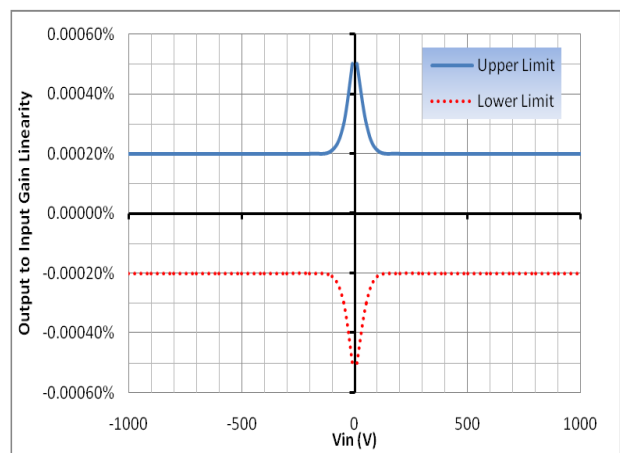

Figure 4: Gain Nonlinearity

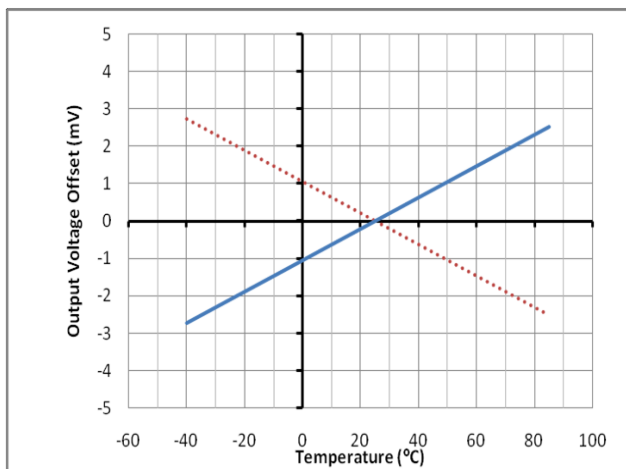

Figure 5: Output Voltage Drift vs. Temperature

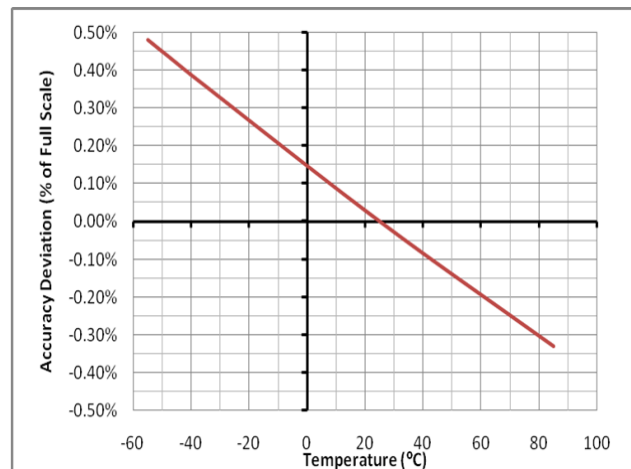

Figure 6: Gain Percentage Deviation vs. Temperature

PERFORMANCE CHARACTERISTICS (-Continue)

At $T_A = +25^\circ\text{C}$, $V_{CC} = +12\text{V}$, $V_{EE} = -12\text{V}$, and $R_L = 10\text{k}\Omega$, unless otherwise noted

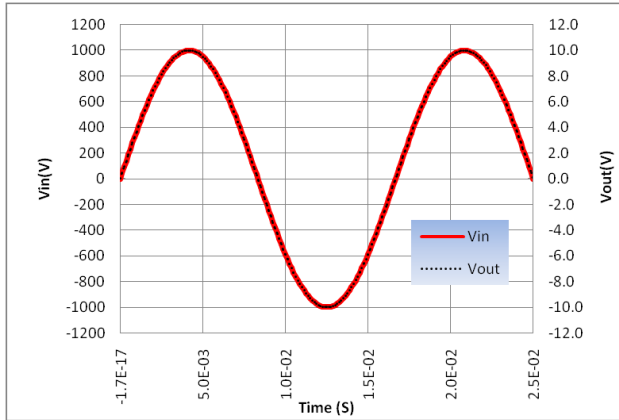

Figure 7: 60Hz Response

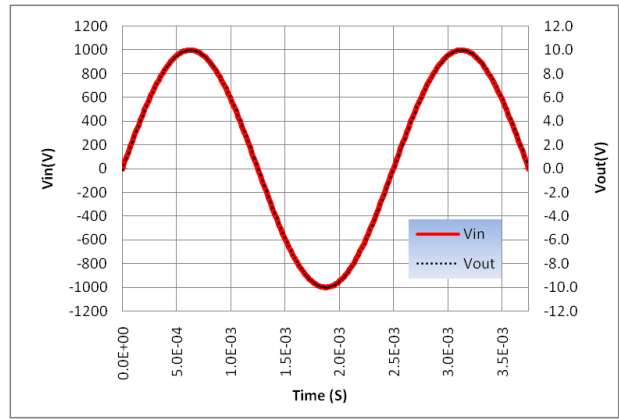

Figure 8: 400Hz Response

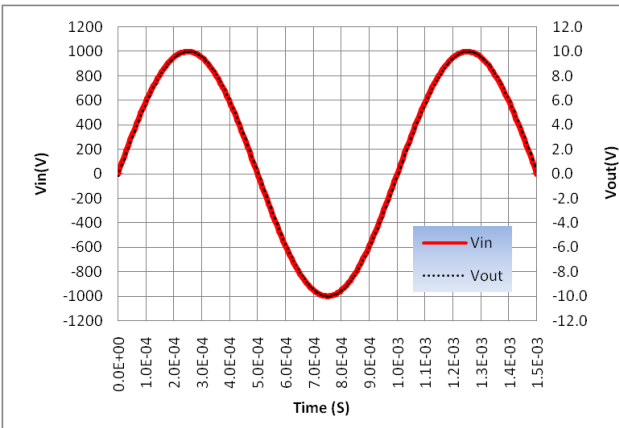

Figure 9: 1KHz Response

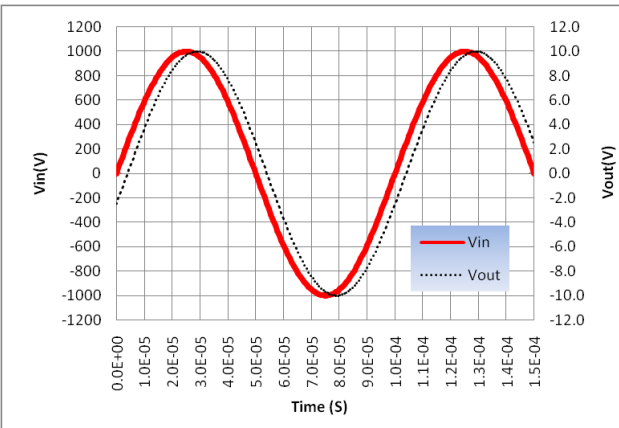

Figure 10: 10KHz Response

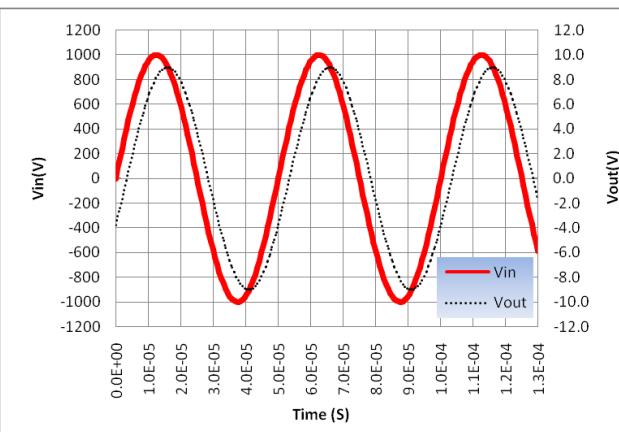

Figure 11: 20KHz Response

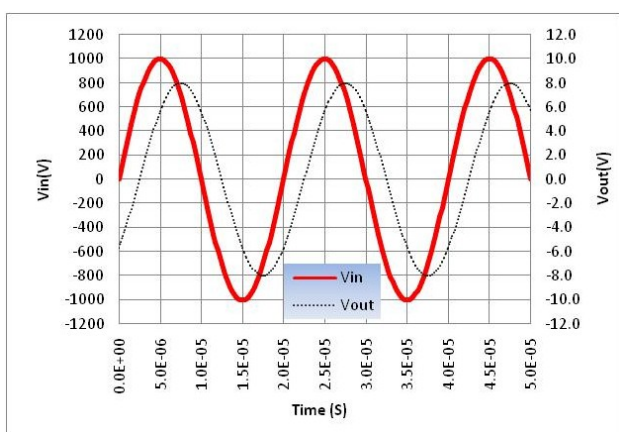

Figure 12: 50KHz Response

PERFORMANCE CHARACTERISTICS (-Continue)

At TA = +25°C, Vcc = +12V VEE=-12V, and RL = 10kΩ, unless otherwise noted

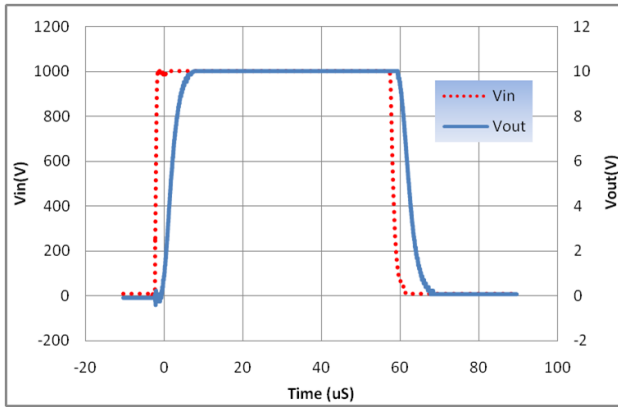

Figure 13: 1000V Input Step Response

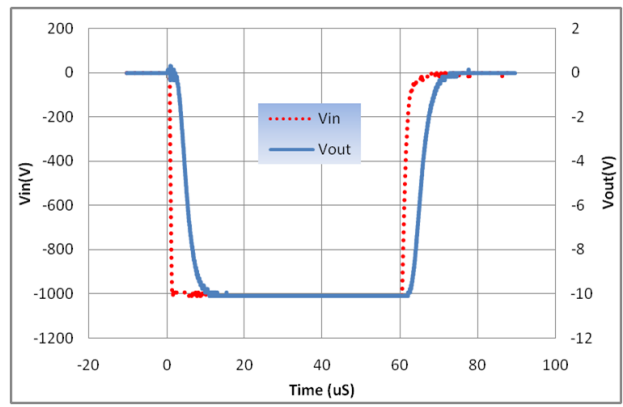

Figure 14: -1000V Input Step Response

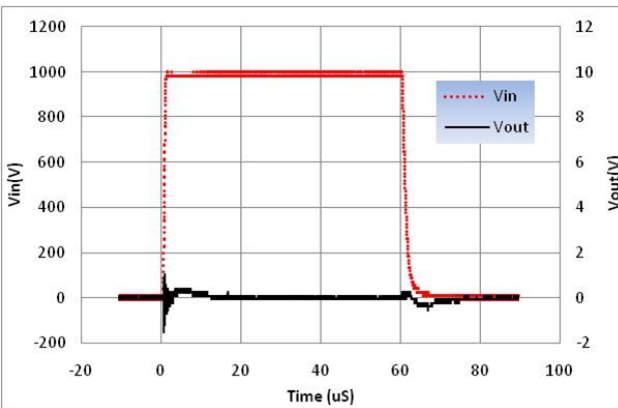

Figure 15: 1000V Common Mode Rejection Response

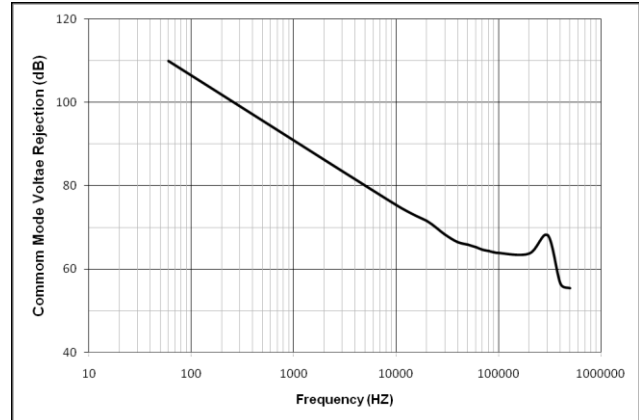

Figure 16: Common Mode Frequency Response

Note:

1. The 4200Vrms 60Hz is applied between shorted high voltage pins (“+” and “-”) and shorted low voltage pins (VCC, VEE, GND, VOP and VON) for a duration of 60 seconds at room temperature. Passing criteria is less than 40 µA. Each device is 100% tested by this test.
2. Isolated output voltage (pin “VOP” - pin “VON”) is plotted as a function of high voltage input (pin “+”- pin “-“). Gain is defined as the ratio of output voltage (pin “VOP” – pin “VON”) and input voltage (pin “+” - pin “-“).
3. Overall accuracy is defined as voltage error between measured output voltage and actual input voltage divided by 100, expressed as a percentage of the full-scale differential output voltage.
4. Gain vs. temperature is defined as gain deviation from the gain at 25°C, expressed as a percentage per degree C over the operating temperature range of -40°C to 85°C.
5. Nonlinearity is defined as gain deviation from the best-fit gain line, expressed as a percentage of the full-scale differential output voltage.

6. See figure 19 for common mode rejection frequency response test setup.
7. See figure 20 for common mode rejection transient immunity test setup.
8. This is continuous voltage operation range. Maximum DC voltage operation is ± 1000V. Maximum AC voltage operation is 707 Vrms. The amplitude of the AC voltage is $1.414 \times 707 = 1000V$ for 707 Vrms.
9. The output voltage offset drift is defined as voltage deviation from the offset measured at 25 °C with zero input voltage, expressed as per degree C over the operating temperature range of -40°C to 85°C.
10. This is the output voltage response for a sinusoidal input voltage with fixed amplitude of 1000V and frequency from 60Hz to 50 KHz.
11. The propagation delay is the time delay between input voltage applied and output voltage starts to respond. Slew rate is the output voltage linearly increased in volts per micro second when a voltage input step is applied.
12. Calculation of MTBF (Mean Time Between Failure) is based on Mil-HDBK-217F Notice 2.

TEST SETUP

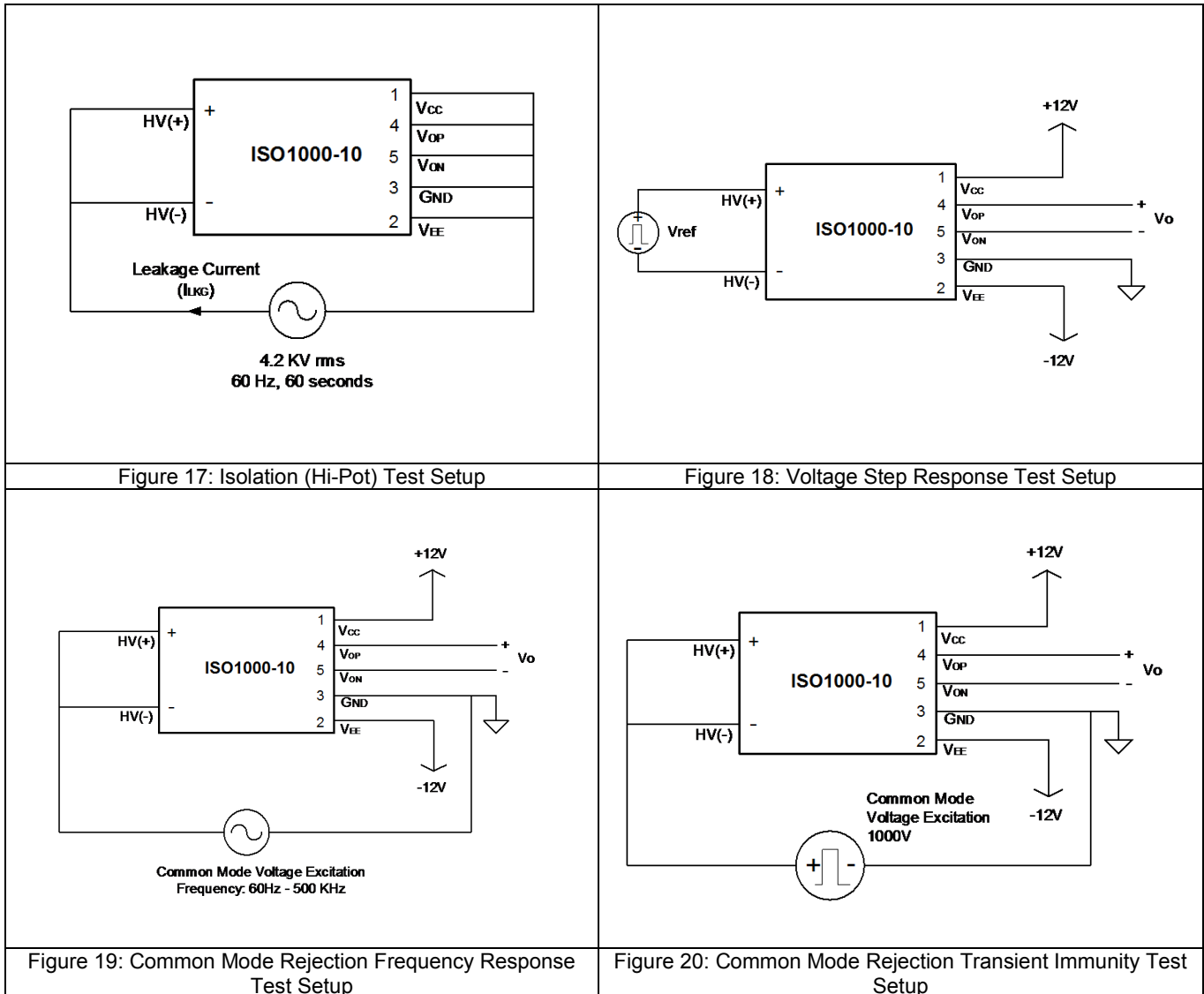

PACKAGE OUTLINE

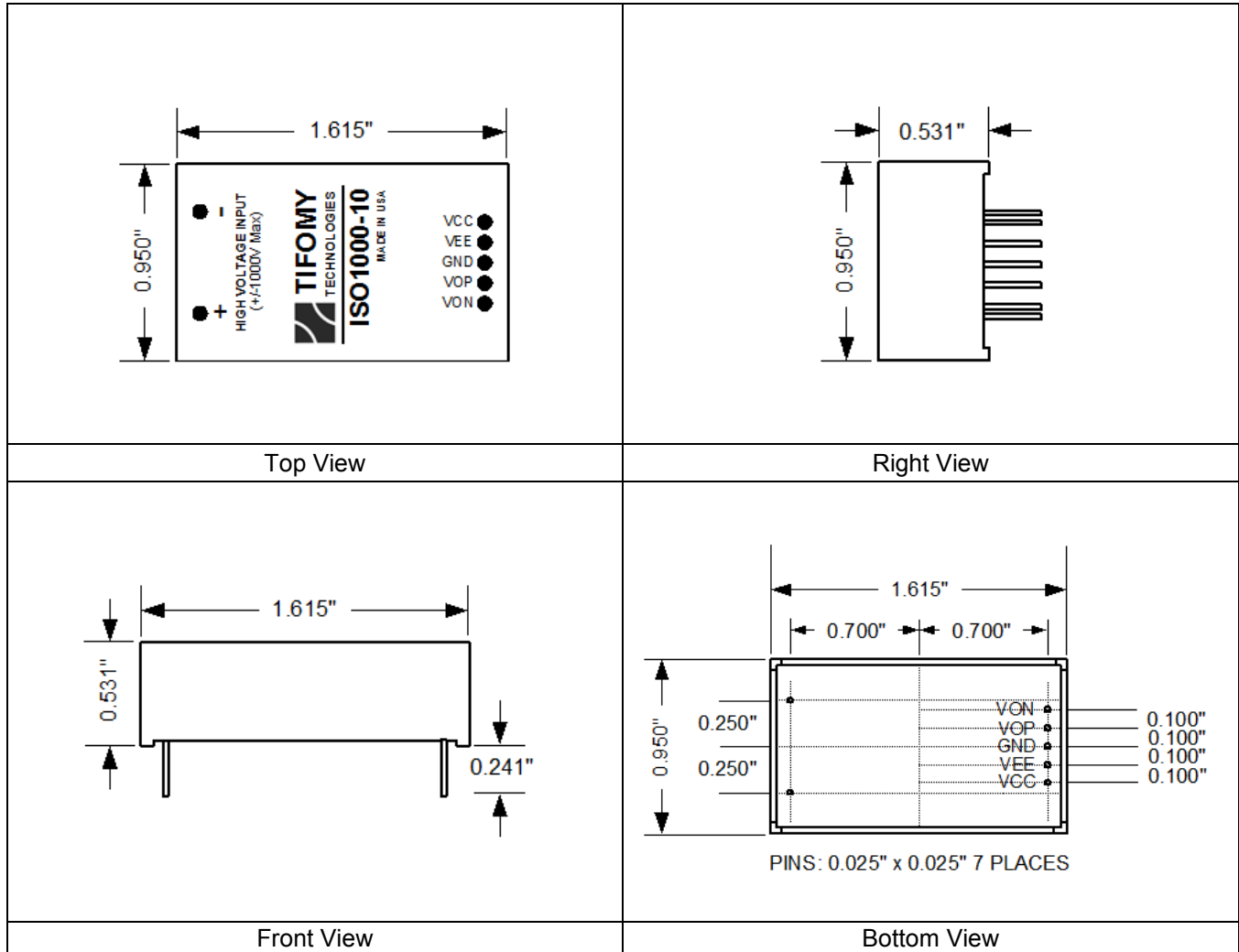

PACKAGE WEIGHT

0.776 OZ (22 g)

WARNING!

 <p>Danger! Electrical Shock Risk</p>	<p>The exposed pins of the voltage transducer can carry hazardous voltage. The device must be used in a protective housing and the conducting parts must be inaccessible after installation. Ignoring this warning can lead to injury and/or serious damage.</p>
---	--

IMPORTANT NOTICE

Tifomy Technologies Incorporated (Tifomy) disclaims any and all liability for any errors, inaccuracies or incompleteness contained in any datasheet or in any other disclosure relating to any product. Tifomy reserves the right to make corrections, modifications, enhancements, improvements, and other changes to its products at any time and to discontinue any product without notice.

All products are sold with standard warranty subject to Tifomy's terms and conditions of sale supplied at the time of order acknowledgment.

Unless expressly authorized in writing by the President of Tifomy Technologies, Inc, Products are not designed, intended or authorized for use as critical components in life support or safety devices or systems, or for any other application in which the failure of the Products could create a situation where personal injury or death may occur.